

ROUES JOCKEY

JOCKEY WHEELS

TÉLÉSCOPIQUES - ELECTRO-ZINGUÉES DE SÉRIE



1200218 R.J. Ø48
(Poids : 4,7kg)



1200870 R.J. Ø48
RENFORCÉE (Poids : 7,3kg)



1200220 R.J. Ø60
(Poids : 9,1kg)



1200222 à boulonner
COULISSEAU Ø48



1200222M MOULÉ
COULISSEAU Ø48



1200223 à boulonner
COULISSEAU Ø60



1200222S : à souder
COULISSEAU Ø48
Base brute

RÉF.	CHARGE Statique (kg)	H mini mm	Course mm	ØD mm	Roulette ØA x B	C mm
1200218	100	390	220	48	200x40	130
1200870	125	505	230	48	200x40	130
1200220	150	420	285	60	220x70	150

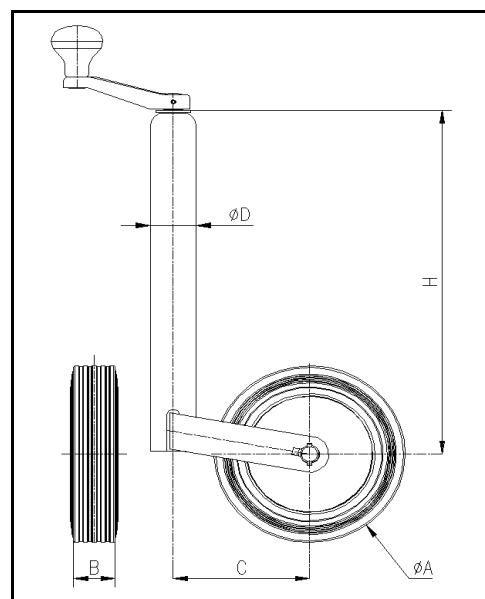

ROUES JOCKEY " SPÉCIALES "

SPECIAL JOCKEY WHEELS

TÉLÉSCOPIQUES - ELECTRO-ZINGUÉES DE SÉRIE



1200836 R.J. - BEQUILLE Ø48 À MANIVELLE LATÉRALE
Charge statique = 100kg (Poids : 8,7kg)

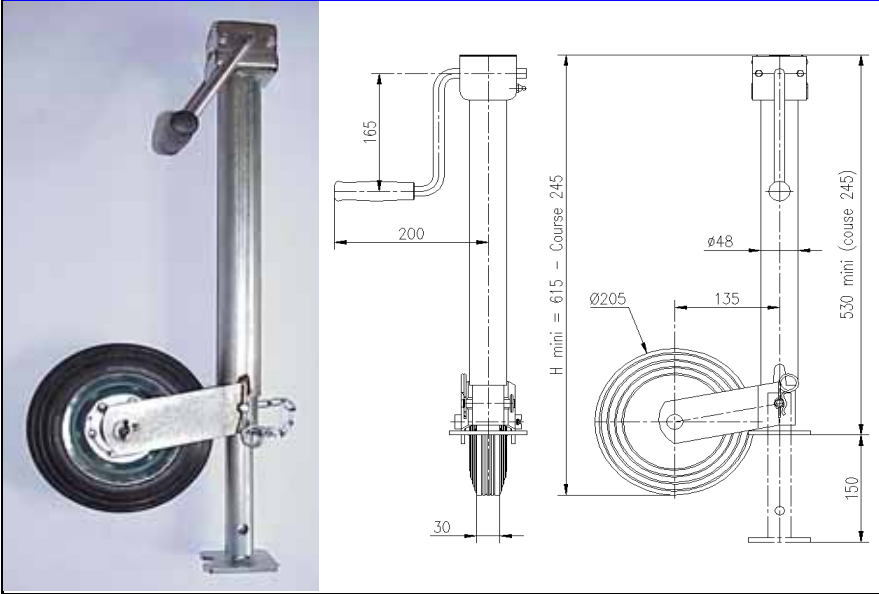

1200357 R.J. Ø48 RENFORCÉE
Charge statique = 250kg (Poids : 11kg)



1200328 R.J. Ø60 AUTOMATIQUE ET ESCAMOTABLE
Charge statique = 150kg (Poids : 10,5kg)

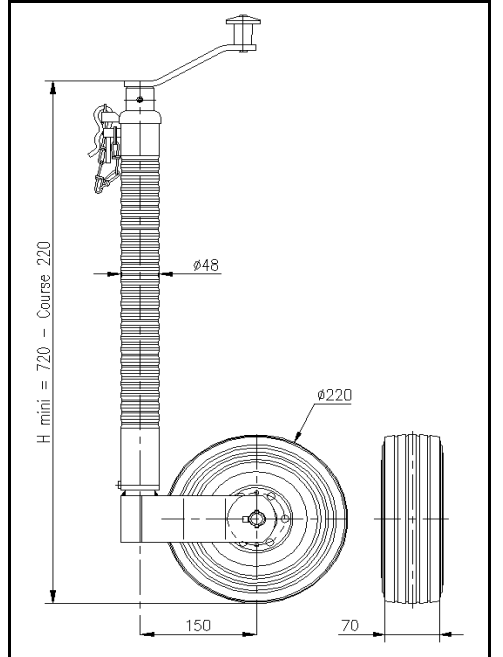
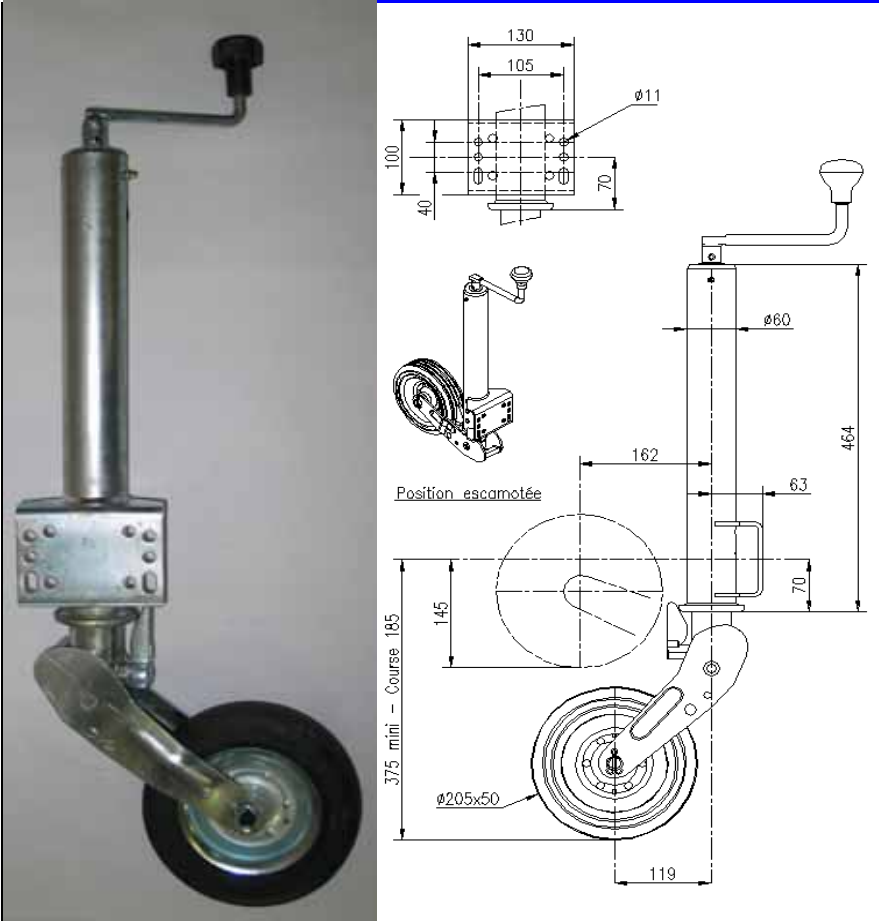

1200358 COULISSEAU Ø48
Pour roue jockey à gorges



ROUES JOCKEY " T.P. "

JOKEY WHEELS " CIVIL ENGINEERING "

TÉLÉSCOPIQUES ET ESCAMOTABLES - ELECTRO-ZINGUÉES DE SÉRIE



1200146P7 R.J. Carré 70
(Poids : 14,5kg)



1200821 R.J. Carré 70
(Poids : 14,5kg)

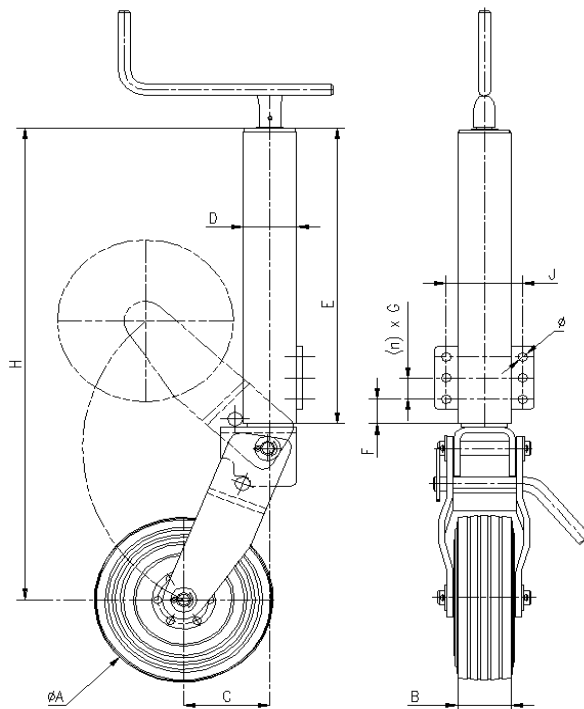

RÉF.	CHARGE Statique (kg)	H mini		C (1 ou 2)		Course mm	D mm	Roulette ØA x B	E mm	FIXATION			
		C(1)	C(2)	(1)	(2)					F	(n) x G	J	Ø
1200146P7	600	671	577	113	212	290	Carré 70	200 x 85	420	Sans platine de fixation			
1200821	600	671	577	113	212	290	Carré 70	200 x 85	420	35	(2) x 30	100	13

1200811 R.J. Ø 70
Charge statique 800kg

(Poids : 24,3kg)

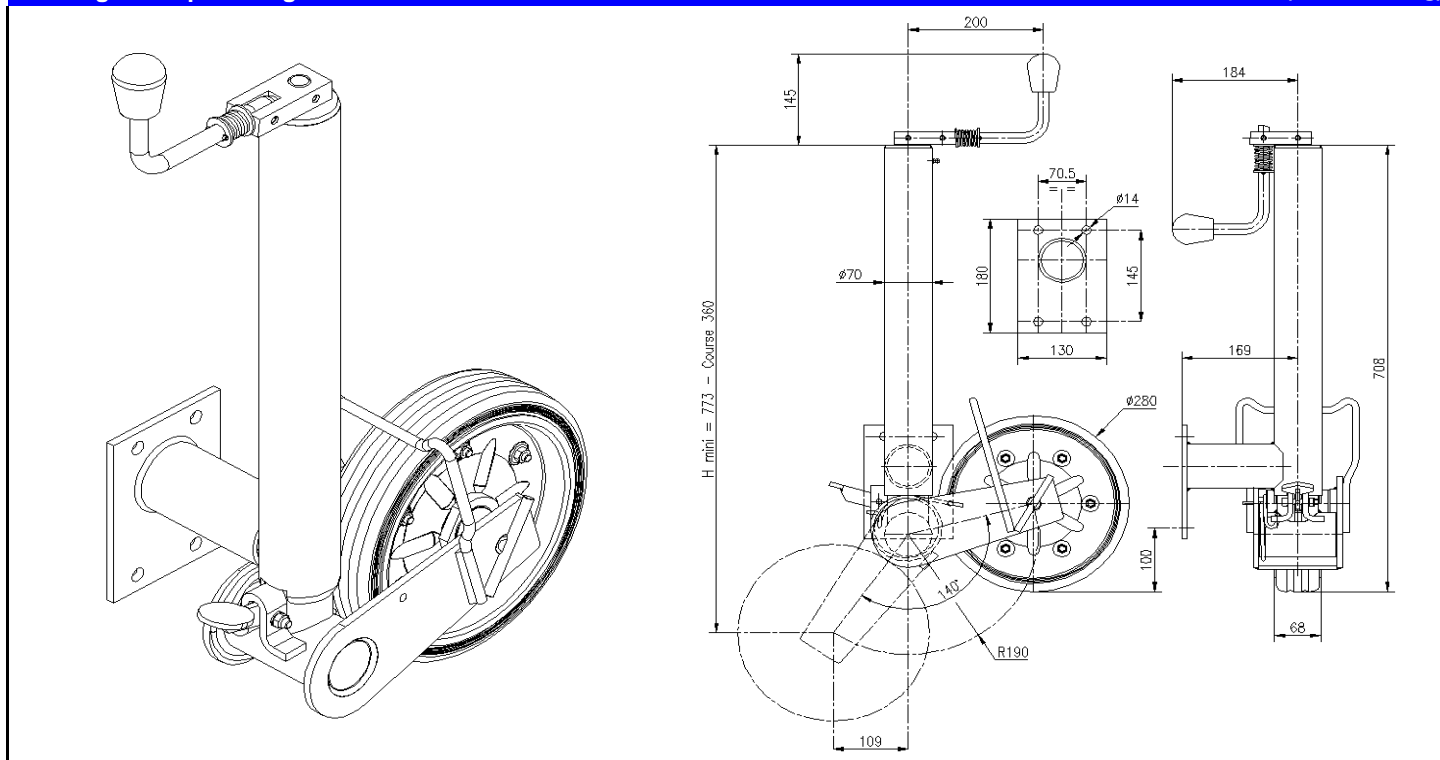

BEQUILLES PROP STANDS

ELECTRO-ZINGUÉES DE SÉRIE (sauf *)



1200827 BÉQUILLE Ø42
Charge statique = 75kg
(Poids : 1,7kg)

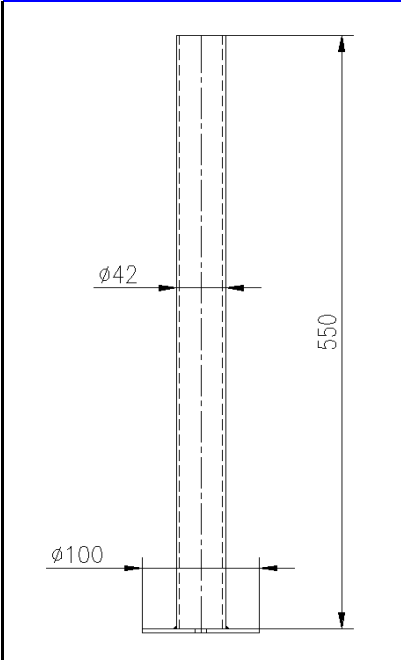

En OPTION: **1200027**
COULISSEAU Ø42

1200232 BÉQUILLE Ø48
Charge statique = 75kg
(Poids : 2,2kg)

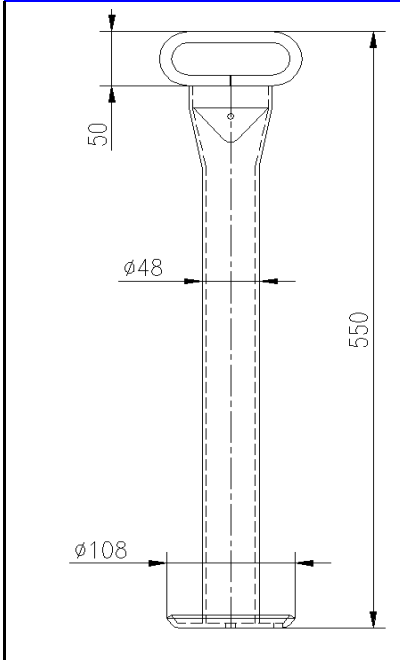

En OPTION: **1200222**
COULISSEAU Ø48

1200390 BÉQUILLE Ø48
Charge statique = 100kg
TÉLÉSCOPIQUE (Poids : 3,5kg)

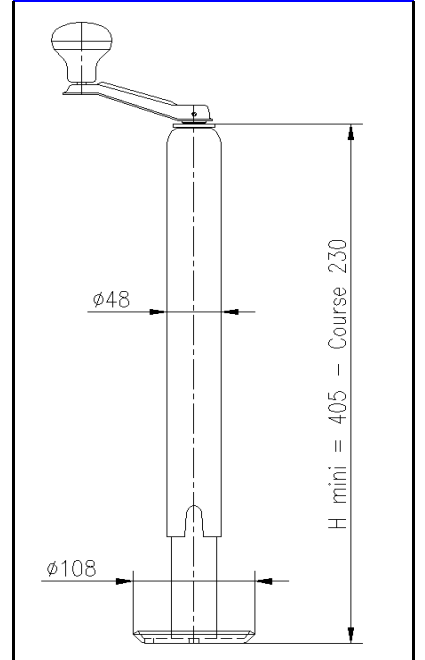

En OPTION: **1200222**
COULISSEAU Ø48

1200823 (Gche) BÉQUILLE Carré 40
Charge statique = 100kg
avec support à boulonner (Poids : 4kg)

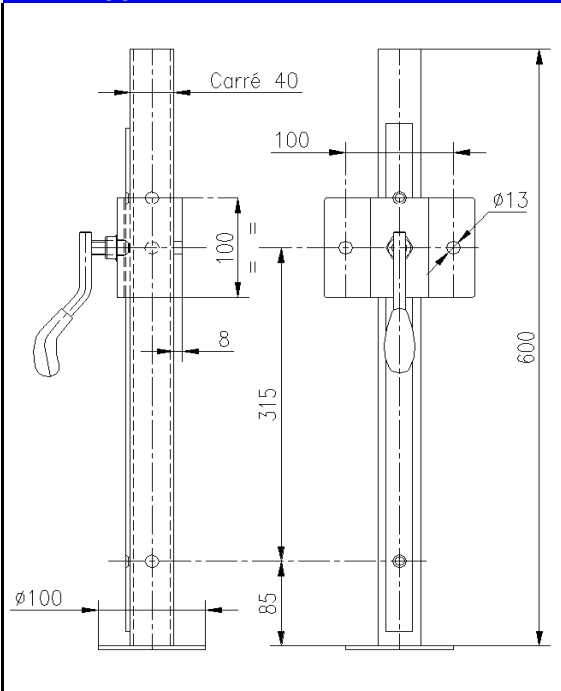

1200822 (Dte) BÉQUILLE Carré 40
Charge statique = 100kg (avec broche)
avec support (*) Dt ou Gche à souder (Poids : 4kg)

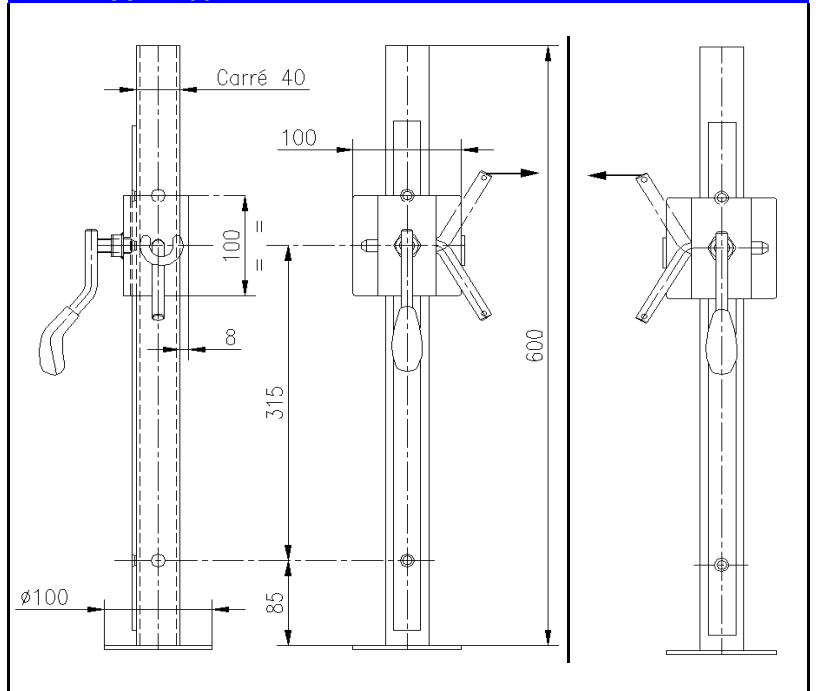

BEQUILLES PROP STANDS

TÉLÉSCOPIQUES - ELECTRO-ZINGUÉES DE SÉRIE (sauf *)



1200824 BÉQUILLE Carré 50
Charge statique = 100kg
(Poids : 7,7kg)

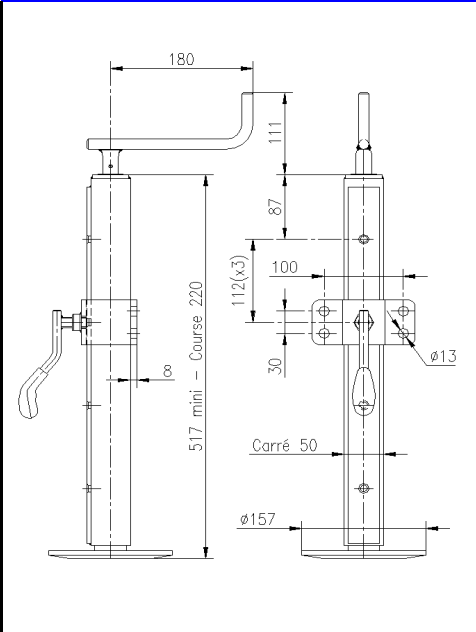

1200393
(voir 1200394)
SANS SUPPORT

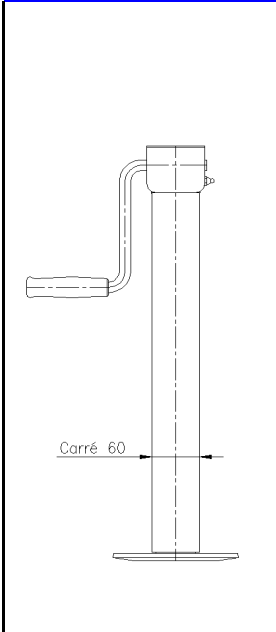

1200394 BÉQUILLE Carré 60
Charge statique = 200kg
AVEC SUPPORT ==> BASCULANTE (Poids : 9,2kg)

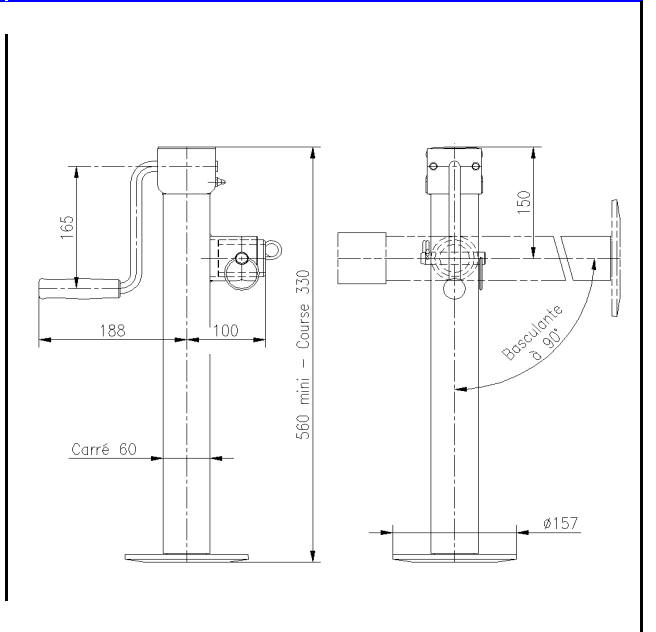

1200825 BÉQUILLE Carré 70
Charge statique = 350kg
(Poids : 12,6kg)

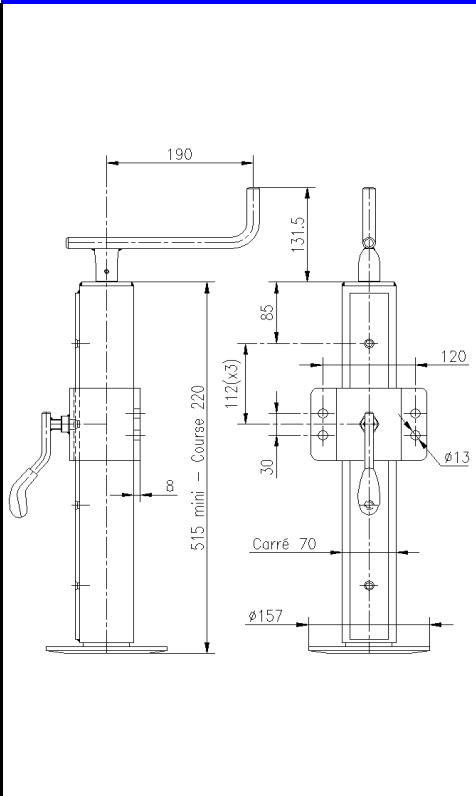

1200834 BÉQUILLE Carré 70
Charge statique = 200kg
(Poids : 13,1kg)

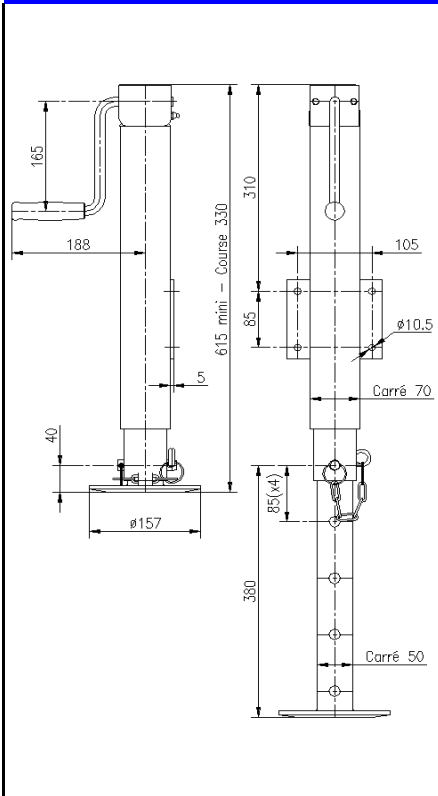

1200835 BÉQUILLE Carré 80(*)
Charge statique = 1000kg
(Poids : 21,4kg)

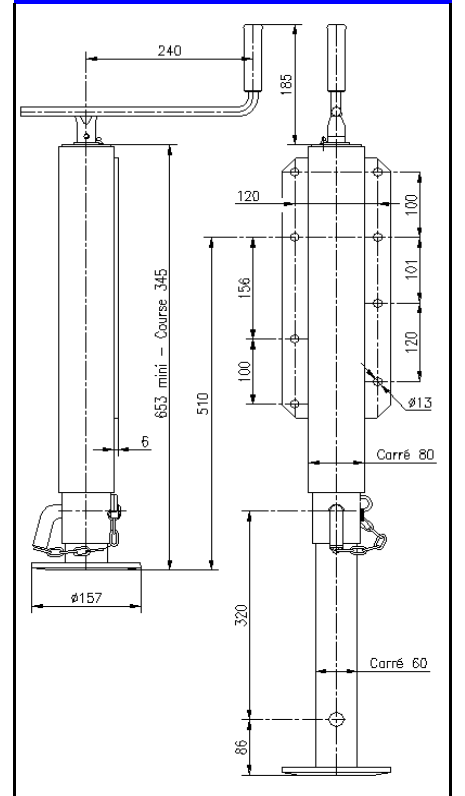

LEVIERS DE PARC

HAND BRAKE LEVERS



1200893 LEVIER DE FREIN DE PARC
Effort de traction = 350kg
Course = 60mm

(Poids : 1,55kg)

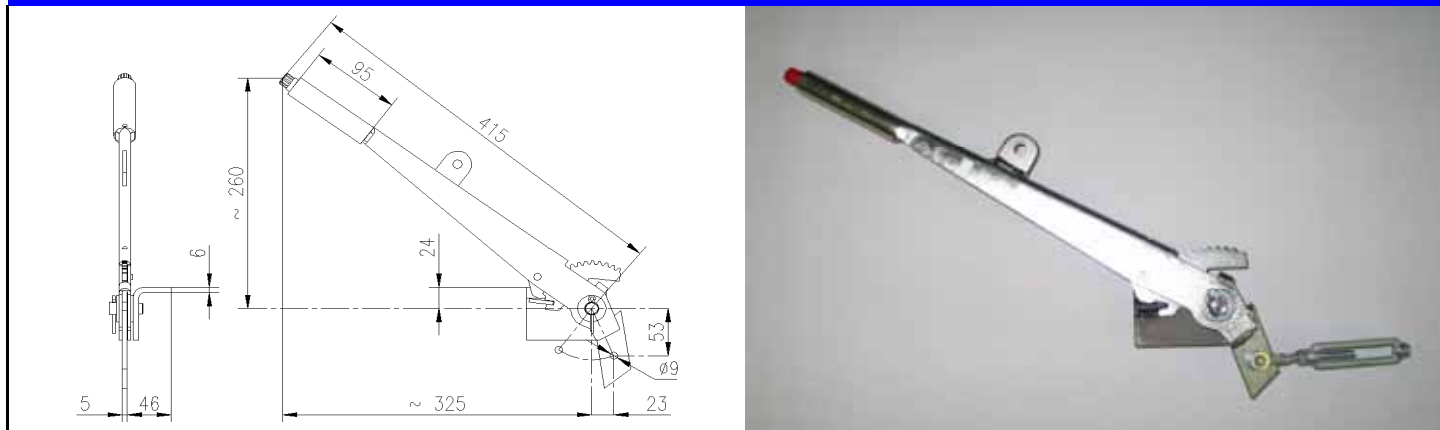

1200814 LEVIER DE FREIN DE PARC
Effort de traction = 350kg
Course = 50mm (Poids : 1,74kg)

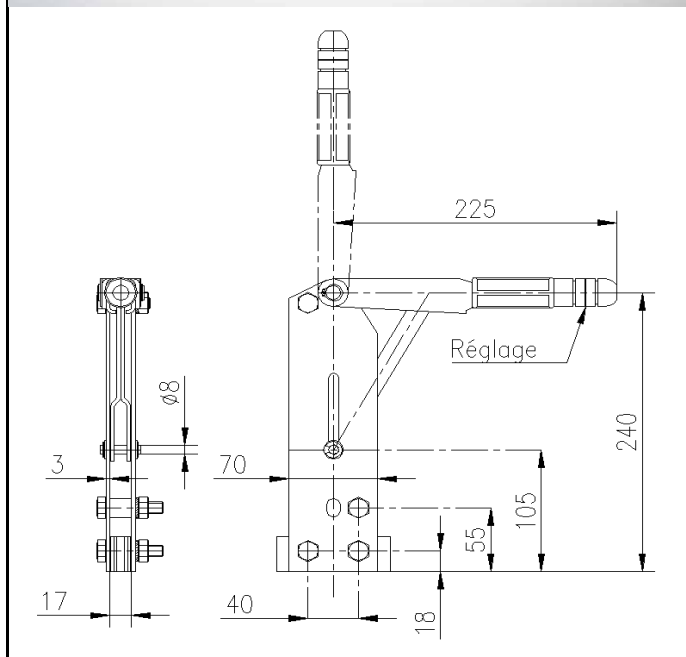

1200033 VIS DE MÉCANIQUE
Effort de traction = 1350kg
Course = 185mm (Poids : 3,55kg)

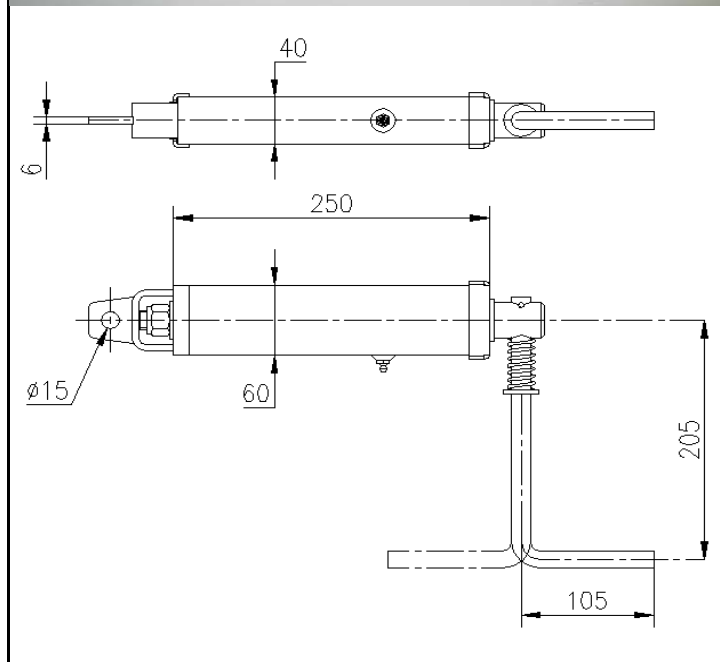

RONDS D'AVANT-TRAIN À BILLES

BALL BEARING TURNTABLES

VITESSE ROUTIÈRE

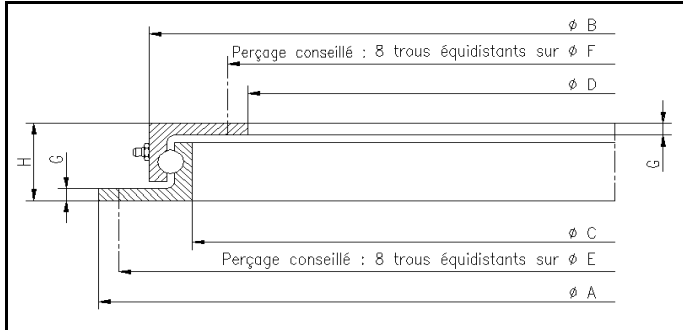

RÉF.	CHARGE Axiale	A mm	B mm	C mm	D mm	E mm	F mm	G mm	H mm	Information	Poids kg
1373000	1.8 t	500	437	384	315	475	340	8	52		17
1374000	2.5 t	650	587	534	465	625	490	8	52		23
1375000	3 t	750	687	634	565	725	590	8	52	LIVRÉS	28
1376000	3.5 t	850	787	734	665	825	690	8	52	NON PERCÉS	32
1377000	4 t	950	887	834	765	925	790	8	52		36
1378000	4.5 t	1050	987	934	865	1025	890	8	52		40

À 25 km/h augmenter la Charge Axiale de 30 à 50%

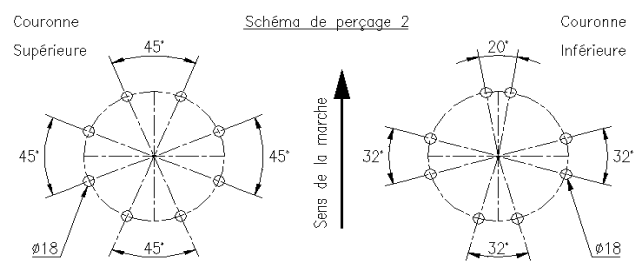
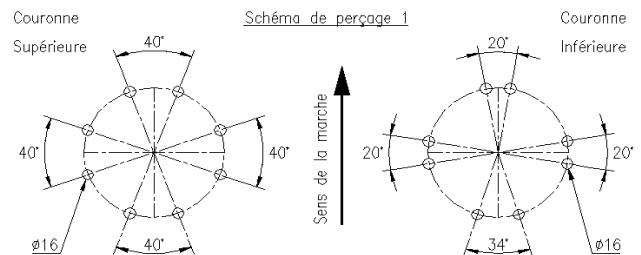
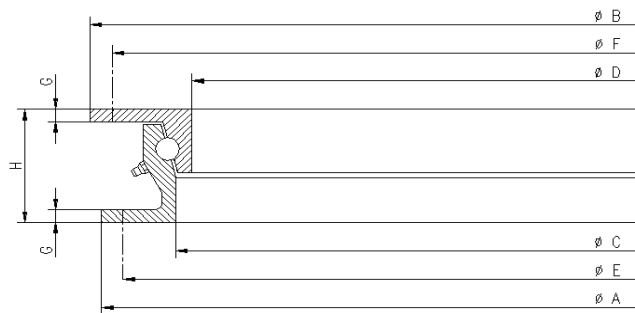

RÉF.	CHARGE Axiale	A mm	B mm	C mm	D mm	E mm	F mm	G mm	H mm	PERCÉ Suivant Schéma	Poids kg
1379000	3 t	685	700	588	567	657	671	9	80	non percé	32
1380000	5 t	880	895	783	762	852	866	9	80	1	43
1381000	6 t	1000	1015	903	882	972	986	9	80	non percé	48
1382000	6.5 t	1090	1105	993	972	1060	1074	9	80	2	52
1383000	7 t	1000	1011	886	859	960	974	10	90	non percé	63
1384000	8 t	1100	1111	986	959	1060	1074	10	90	2	69
1386000	10 t	1100	1111	986	959	1060	1074	10	90	2	69
1388000	12 t	1100	1111	986	959	1060	1074	10	90	2	69
1389000	13 t	1200	1211	1086	1059	1160	1174	10	90	2	76

À 25 km/h augmenter la Charge Axiale de 20%

AILES DE ROUE

MUDGUARDS

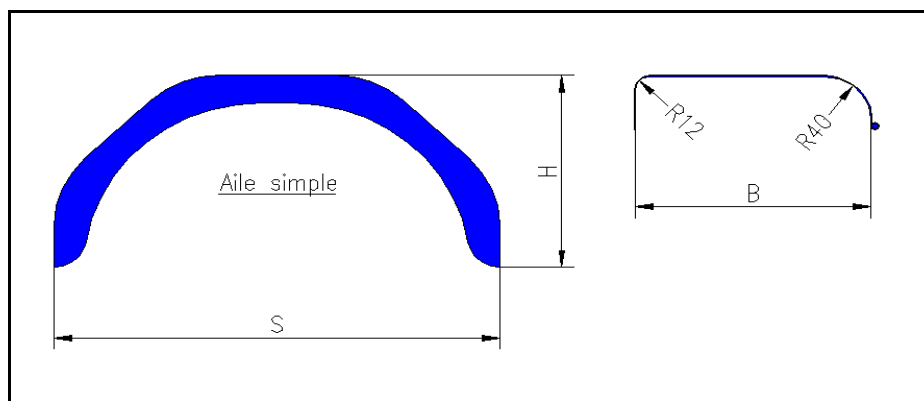

RÉF.	TYPE	ROUES	Matière	Protection	ENCOMBREMENT			Poids kg
					B	S	H	
2372055 simple	HMHR 1966	12" , 13"	Tôle	Galvanisé	190	660	340	2,3
2372056 simple	HMHR 2075	13" , 14"	Tôle	Galvanisé	200	750	350	2,6
2372062 simple	HMHR 2280	14" , 15"	Tôle	Galvanisé	220	800	370	2,9
2372063 double	THMHRD 20140	12" , 13"	Tôle	Galvanisé	200	1400	350	3,9
2372064 double	THMHRD 23152	14" , 15"	Tôle	Galvanisé	230	1520	400	4,8
2372191 double	THMHRD 26150		Tôle	Galvanisé	260	1500	370	5,3

